

MATERIALS:
 INSULATOR:P.B.T.30%GLASS FIBER,UI94V-0
 CONTACT MATERIAL:BRASS OR PHOSPHOR BRONZE,
 GOLD FLASH OVER NICKEL

ELECTRICAL:
 CURRENT RATING:2AMP.
 INSULATION RESISTANCE:5000M Ω MIN.
 DIELECTRIC WITHSTANDING:500VAC
 OPERATING TEMPERATURE:-45°C~+105°C

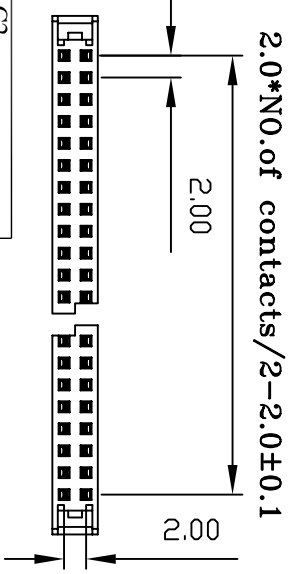
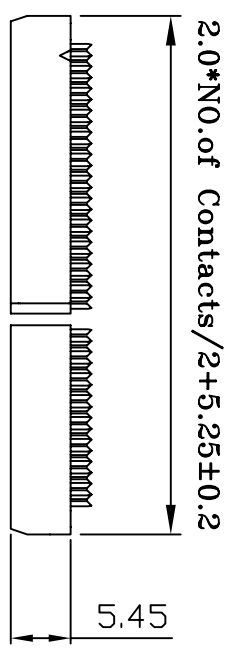
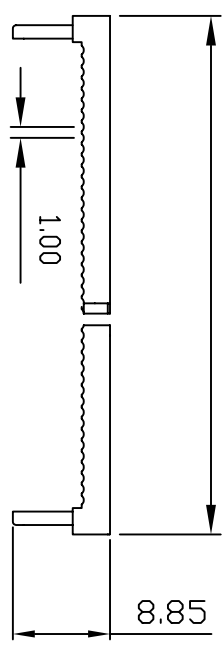
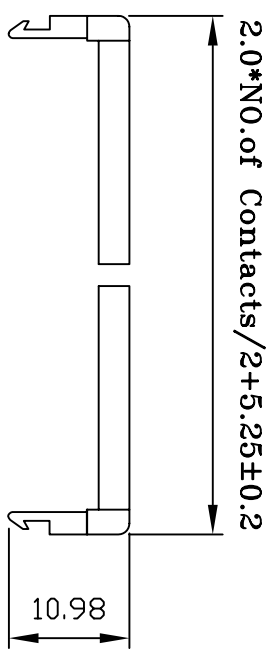
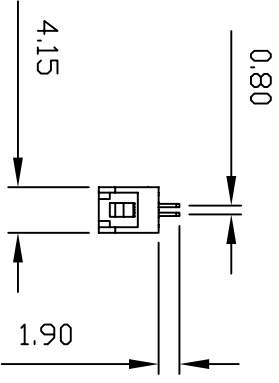
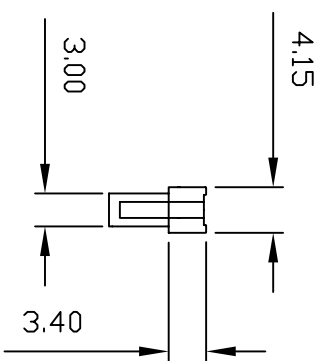
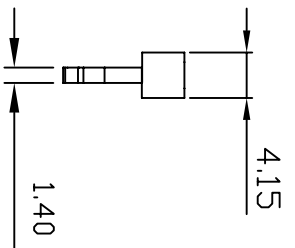
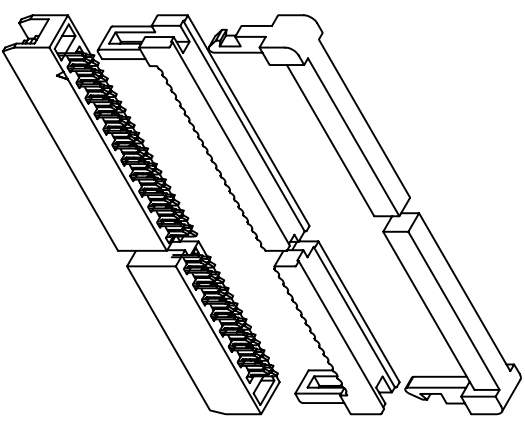

FC-223 - XX P0 BK C 000 C
 1 2 3 4 5 6

- (RoHS Compliant)
- Circuits:
 ◎:10 to 50pin
 - Material:
 P0=Phosphor Bronze
 BK=Black
 GR=Gray
 - Contact Plated:
 T=Tin over Nickel
 - Contact Plated:
 C=Gold Flash
 F=Gold Flash,Tin 100u"
 A=Gold 3u"
 B=Gold 3u",Ni 100u"
 D=Gold 5u"
 E=Gold 5u",Ni 100u"
 - Special Options
 - Packing: C=Tray
- G=Gold 10u"
 J=Gold 10u",Ni 100u"
 L=Gold 15u"
 M=Gold 15u",Ni 100u"
 U=Gold 30u"
 V=Gold 30u",Ni 100u"
 N=Gold Flash , Ni

◎:06 to 68pin-2009/02/18-C2		PART NO		FC-223-XXP0BK C000C		.X ±0.3		.XX ±0.20		.XXX ±0.100	
◎:FC-223-XXP0BK C000-2007/05/22-C1		DRAWING NO		FA-00040		EDITION: C3		ITEM: FA		SCALE: 1:1	
◎:FC-22-XXXB0BK N000-2007/04/23-C		DRAWN BY		GARY		2009/05/11		SCALE: 1:1		UNIT: m.m	
TEL:(02)86481727 FAX:(02)86482427		COMPONENT INC.		APPROVAL BY							
BOM		1: FC-24-XXBKM0		DRAWING NO		FA-00040		EDITION: C3		ITEM: FA	
		2: FC-23-XXBKS R		DRAWN BY		GARY		2009/05/11		SCALE: 1:1	
		3: FC-22-XXBKH0		4: FAT-AP		APPROVAL BY					

4 號-紙箱

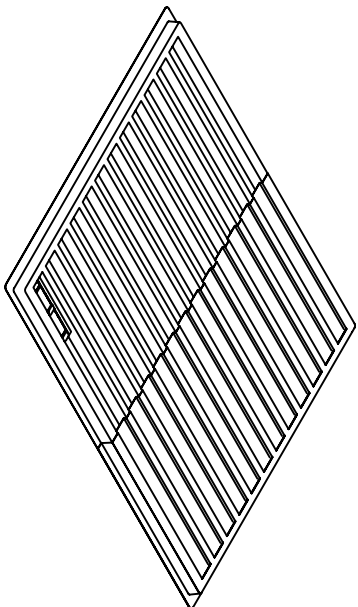
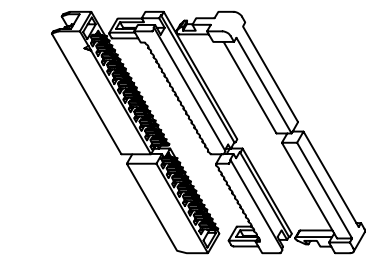
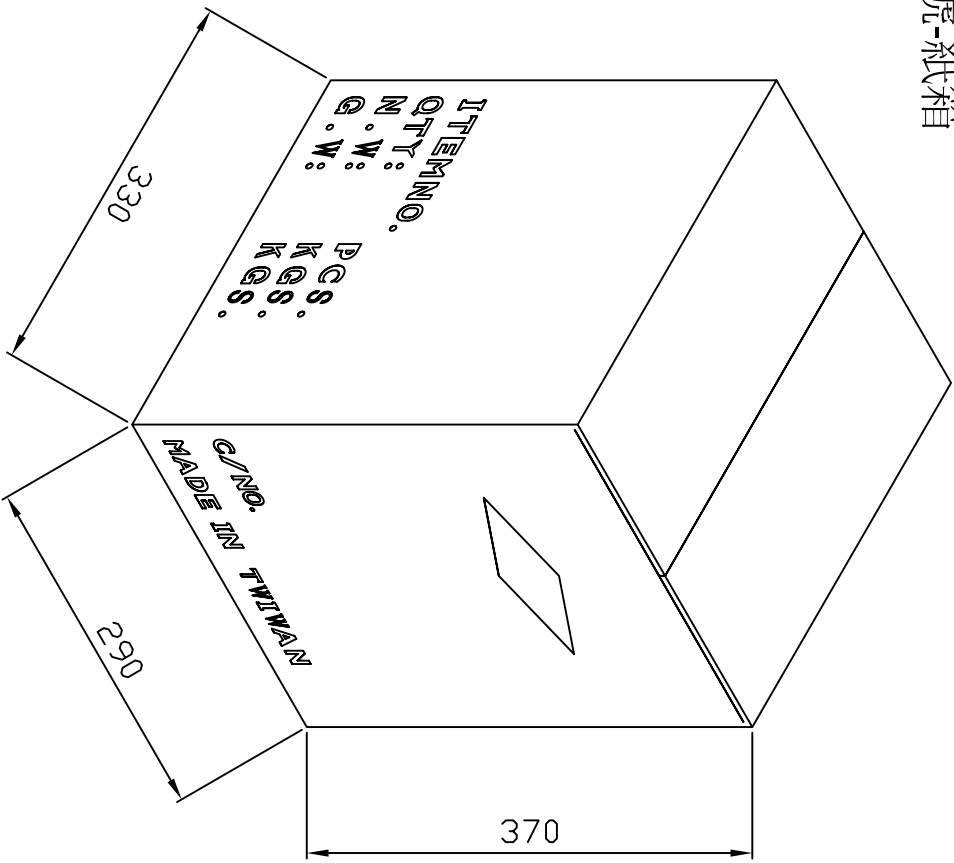

DIMENSIONS

PART NO	CONTACTS	TRAY	CARTON	KGS	
				N.W	G.W
FC-21-10B0BK000	FC-10P	216	12960	14.0	15.0
FC-21-12B0BK000	FC-12P	192	11520	14.0	15.0
FC-21-14B0BK000	FC-14P	168	10080	13.5	14.5
FC-21-16B0BK000	FC-16P	156	9360	14.0	15.0
FC-21-20B0BK000	FC-20P	132	7920	14.5	15.5
FC-21-24B0BK000	FC-24P	108	6480	13.5	14.5
FC-21-26B0BK000	FC-26P	96	5760	13.5	14.5
FC-21-30B0BK000	FC-30P	84	5040	10.5	13.5
FC-21-34B0BK000	FC-34P	84	5040	14.0	15.0
FC-21-40B0BK000	FC-40P	72	4320	13.5	14.5
FC-21-44B0BK000	FC-44P	60	3600	12.5	13.5
FC-21-50B0BK000	FC-50P	60	3600	14.5	15.5

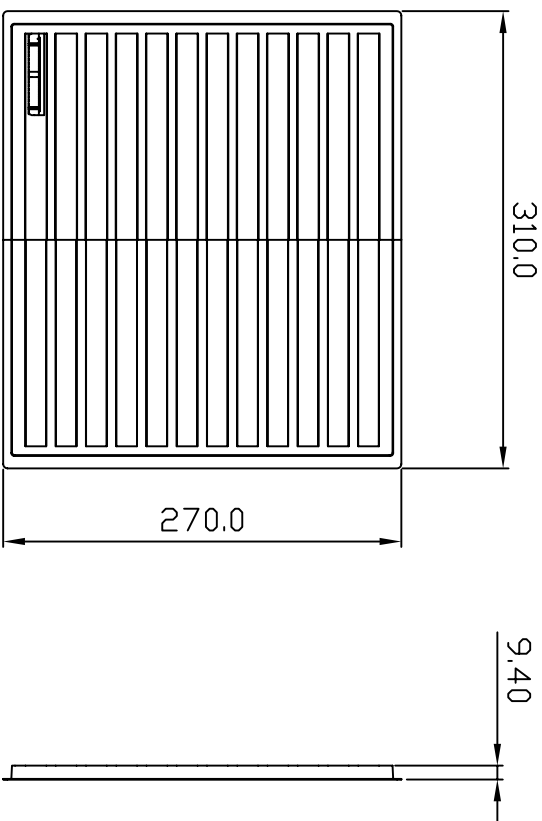

CONN TOP
COMPONENT INC.

PART NO

FC-223-XXP0BK000C
(Tray)

X ±20.0
X ±0.50
XX ±0.50

1:

0

DRAWING NO

BOX-00007

EDITION: C

BOM 2:

0

DRAWN BY

GARY

2007/10/02

TEL: (02)86481727 FAX: (02)86482427

APPROVAL BY

SCALE: 1:1
UNIT: mm