

MATERIALS:
 INSULATOR:P.B.T.30%GLASS FIBER,UL94V-0
 CONTACT MATERIAL:BRASS OR PHOSPHOR BRONZE,
 GOLD FLASH OVER NICKEL

ELECTRICAL:
 CURRENT RATING:1AMP.
 INSULATION RESISTANCE:1000M Ω MIN.
 DIELECTRIC WITHSTANDING:500VAC
 OPERATING TEMPERATURE:-45°C~+85°

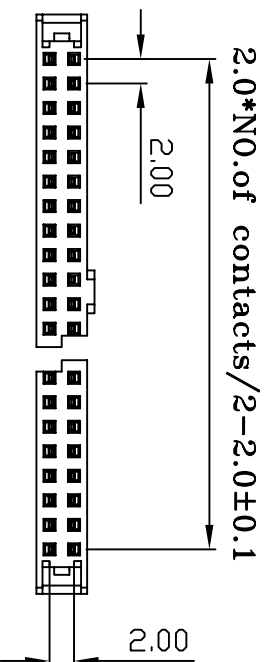
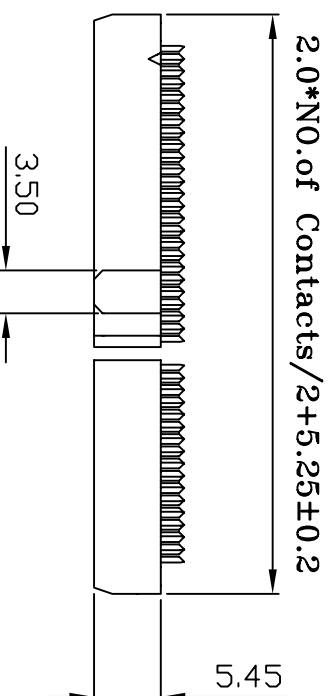
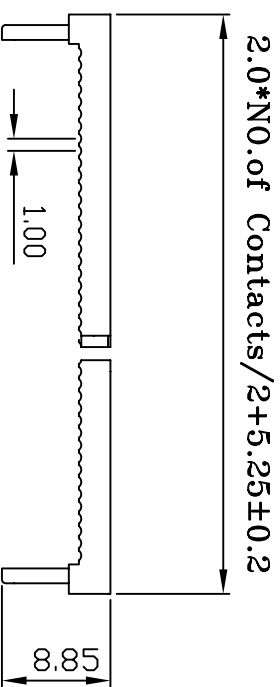
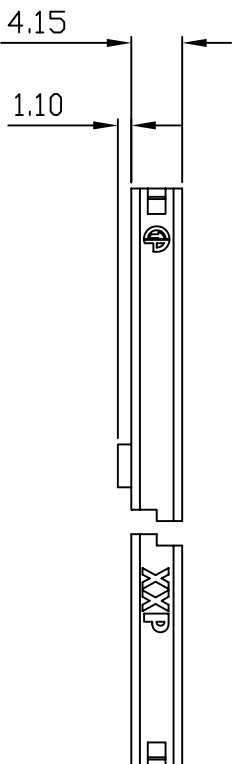
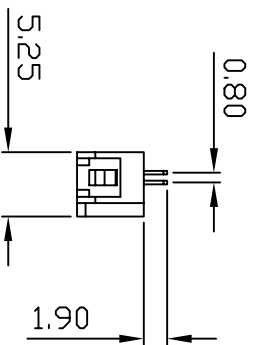
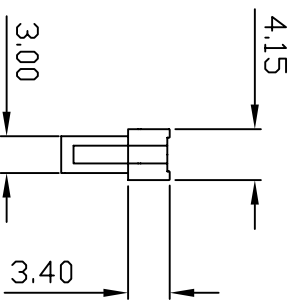
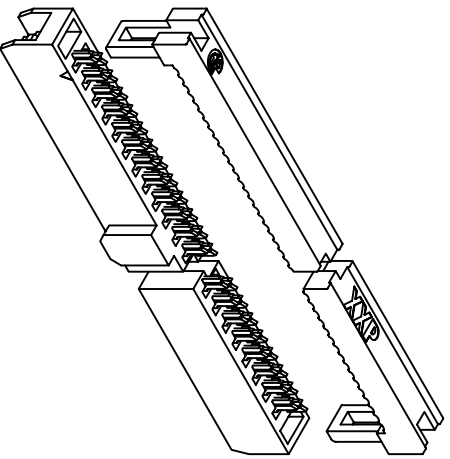

FC-26 - XX P0 BK N 001
 1 2 3 4 5

- (RoHS Compliant)
- Circuits: 06 to 68pin
 - Material:
 - P0=Phosphor Bronze
 - BK=Black
 - GR=Gray
 - Contact Plated:
 - T=Tin over Nickel
 - C=Gold Flash
 - F=Gold Flash,Tin 100u'
 - A=Gold 3u'
 - B=Gold 3u',Ni 50u'
 - D=Gold 5u'
 - E=Gold 5u',Ni 50u'
 - Special Options



CONN TOP
 COMPONENT INC.

PART NO	FC-26-XXXP0BK N001	X	X	.XX
DRAWING NO	FA-00046	±0.2	±0.2	±0.2
DRAWN BY	GARY	ITEM:	SCALE:	FA
EDITION:	2007/05/16	UNIT:		m.m

1: FA-21-XXBKHI
 BOM 2: FC-24-XXBKMI
 3: FAT-AP
 TEL: (02)86481727 FAX: (02)86482427
 APPROVAL BY